

EM Motorsport Ltd
Unit A4 Telford Road
Bicester
Oxon, OX26 4LD
U.K.
Tel: +44 (0) 1869 241977



ADR4 Installation Manual

Revision	Reason	Author	Date	Check by
2.0	ADR4 version, added channel list	V. Dariol	21/08/2019	
2.1	Added serial terminal commands lists.	V. Dariol	22/08/2019	
2.2	Added Test in the command list description at paragraph 2.3	V. Dariol	02/10/2019	
2.3	General Revision + Removed CAN Protocol	I. Gamboa	28/01/2020	
2.4	Clarification on connector pin 6 and 13 both galvanically connected to internal ground.	V. Dariol	06/11/2020	
2.5	Added External LED Response	I. Gamboa	21/01/2021	
2.6	Added reference to FIA	I Gamboa	13/03/2021	V. Dariol
2.7	Added CAN Protocol + Download links	I. Gamboa	01/04/2021	
2.8	General Revision	I. Gamboa	12/04/2021	G. Cooper
2.9	Added FAQ Section	I. Gamboa	15/04/2021	
3.0	Updated CAN Protocol	I.Gamboa	12/12/2021	
3.1	Minor updates	I.Gamboa	31/01/2022	
3.2	Updated LED Scheme	I.Gamboa	14/02/2022	
3.3	Fix Title	I Gamboa	10/06/2022	
3.4	Updated layout	L De Angelis	27/06/2023	

CONTENTS

1	INTRODUCTION	3
2	SYSTEM COMPONENTS AND ARCHITECTURE	4
2.1	LED INFORMATION.....	4
2.2	INTERNAL CHANNELS	5
2.3	SYSTEM SET UP	6
2.3.1	<i>Connection set up</i>	6
2.3.2	<i>List of available commands:</i>	6
3	INSTALLATION GUIDE	8
3.1	ADR4 EQUIPMENT.....	8
4	CAR LOOMS	11
4.1	CHASSIS LOOM	11
4.2	GPS ANTENNA LOOM (OPTIONAL)	11
5	TECHNICAL DESCRIPTION	12
5.1	ADR4 TECHNICAL INFORMATION	12
5.2	ADR4 SYSTEM LOOM TECHNICAL DATA	14
5.2.1	<i>ADR4 terminal</i>	14
6	CAN PROTOCOL	15
6.1	INPUT PACKETS	15
6.1.1	<i>ECU to ADR4 (CAN ID 0x200)</i>	15
6.1.2	<i>ECU to ADR4 (CAN ID 0x204)</i>	15
6.1.3	<i>ECU to ADR4 (CAN ID 0x680)</i>	15
6.1.4	<i>ECU to ADR4 (CAN ID 0x681)</i>	16
6.2	OUTPUT PACKETS	17
6.2.1	<i>ADR4 to ECU (CAN ID 0x7B)</i>	17
6.2.2	<i>ADR4 to ECU (CAN ID 0x81)</i>	17
7	USEFUL LINKS	18
8	CONTACT DETAILS	19

1 Introduction

The EM Motorsport ADR4 system is designed to log data in the event of an accident at a rate of up to 1KHz and uses inbuilt 3-axis +/-500g accelerometer and 3-axis gyroscope. The unit also consists of a 10Hz GPS receiver (L1 +SBAS), a battery backed RTC (Real Time Clock), an internal Flash memory and a rechargeable energy storage that ensures up to 45 seconds of normal operation in case of power failure. Built into the front face of the unit is a RGB LED which can be used to recognize different system situations, such as unit charging, potential incident recorded and other statuses.

To ensure that your ADR installation complies with all FIA requirements, you are requested to follow “8872-2018 ADR - Installation specification” available in the FIA website.

This document serves as an expansion of the aforementioned document, ensuring a correct installation of the ADR4 to ensure the best performance.

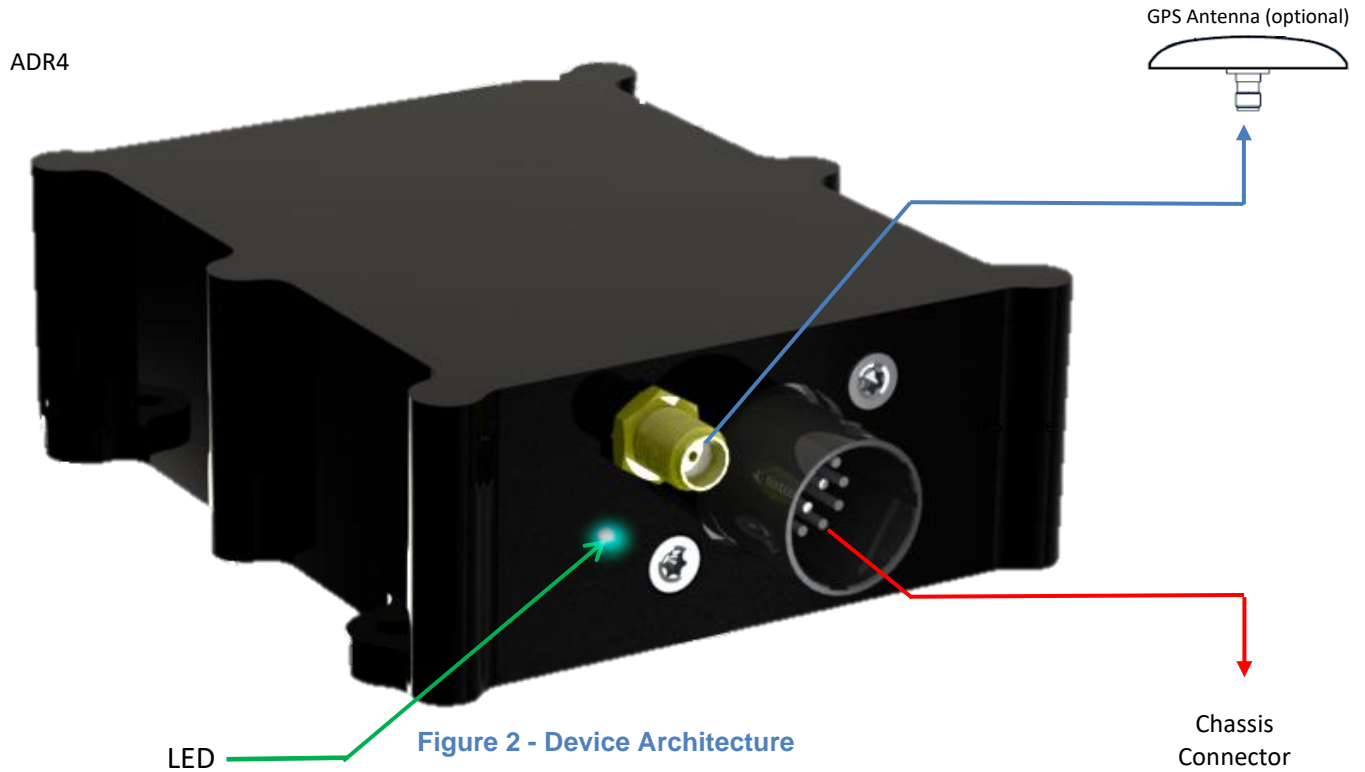

Figure 1 – ADR 4

2 System Components and Architecture

The ADR4 system consists of following items, arranged as shown in **Figure 2 - Device Architecture**:

- ADR4
- GPS Antenna (optional)
- Car Looms
 - GPS Antenna Loom
 - Chassis Loom



2.1 LED information

The Unit has a built in LED to show the unit status. The built-in LED provides relevant diagnostics to the user with the following description:

LED colour	Meaning
4Hz 5% green	logging
solid green	logging + CAN OK
4Hz 5% cyan	logging + unit charging
4Hz 5% Red	accident stored + logging
4Hz 5% yellow	unit charging
4Hz 5% Blue	USB active
4Hz 5% Blue	start up
solid blue	shutting down
solid red	Flash Disk Fault

Table 1 – ADR 4 Operation modes

2.2 Internal channels.

The following tab defines the available internal channels.

Tags	Description	sampling frequency	gain	unit
gADRX, gADRY, gADRZ	Axis acceleration before 8 samples average	1KHz	0.07	not ISO G=9.81m/s ²
nADRX, nADRY, nADRZ	Axis rotation rate	100Hz	0.00875	Degrees.
ORangeX, ORangeY, ORangeZ	Accelerometers Over Range (>500G) time	1KHz	0.2	ms
Temp	Internal temperature	1KHz	0.5	degrees C.
Vbus	USB Voltage	1KHz	0.1	V.
Vbatt	Main supply Voltage	1KHz	0.1	V.
AntI	GPS antenna current	1KHz	1	mA
Lat	GPS Latitude	5Hz	1E-07	Degrees
Lon	GPS Longitude	5Hz	1E-07	Degrees
GPSStat	GPS Status	5Hz		
VGPS	GPS Speed	5Hz	0.01	m/s
HGPS	GPS heading	5Hz	0.01	Degrees
GPSTime	GPS Time	5Hz	0.01	ms
msIntos	analogue channels sampling epoch	1KHz	1	ms.
ASI	Accident Severity Index of the last accident	1KHz	1	not ISO G=9.81m/s ²
D1Freq	Digital input 1 signal frequency	1KHz	1	Hz
D2Freq	Digital input 2 signal frequency	1KHz	1	Hz
D1Count	Digital input 1 pulse count	1KHz	1	--
D2Count	Digital input 2 pulse count	1KHz	1	--
gRawX, gRawY, gRawZ	Axis acceleration before sampling filter	5KHz	0.305	Not ISO G=9.81m/s ²
NAD	number of AD samples in the last second	1Hz	1	--.
NoAD	number of missed AD samples in the last second	1Hz	1	--
NACC	number of accelerometer samples in the last second	1Hz	1	--
NoACC	number of missed accelerometer samples in the last second	1Hz	1	--
ReEnter	number re-entered 20KHz interrupts	1Hz	1	--
CErrors	number accelerometer conversion errors	1Hz	1	--

Tags	Description	sampling frequency	gain	unit
Timer	Supercap hold timer at power removal	10Hz	0.1	s
PowerUp	number of unit power ups	0 Hz	1	--

Table 2 – ADR 4 internal channels

2.3 System set up

It is possible to connect to the serial port of the unit to setup some parameters such as time or orientation. There are 2 different methods to connect to the unit:

- ADR4 Real Time Display: EM Motorsport GUI tool that allows the user to visualize and edit ADR parameters. This tool can be downloaded in our portal, listed in Chapter 7 - Useful Links.
- External Serial Console: Any external serial console (i.e: PuTTY), also allows the user to edit ADR parameters by using the commands listed in 2.3.2.

2.3.1 Connection set up

The serial port has the following parameters:

Protocol: RS232
Speed: 115200
Bits: 8
Parity: N
Start bits: 1

2.3.2 List of available commands:

2.3.2.1 FIA reserved:

Password: command to unlock following commands otherwise not actuated.

AccidentTmeThd: sets the accident detection duration threshold, default value 5ms.

AccidentThdX: sets the accident detection acceleration threshold for X axis, default value 15G.

AccidentThdY: sets the accident detection acceleration threshold for Y axis, default value 15G.

AccidentThdZ sets the accident detection acceleration threshold for Z axis, default value 25G.

AccidentPostTD: sets the minimum accident post trigger time.

2.3.2.2 Setting RTC:

The following commands are used to set the battery back-up RTC

SetRTC: enter the date and time in the following format

Format: dd/mm/yyyy,hh:mm:ss

SetDate: enter the date in the following format

Format: dd/mm/yyyy

SetTime: enter the time in the following format

Format: hh:mm:ss

SetTimeGPS: Command will only work when VBatt is applied, would set the unit time to GPS time.

2.3.2.3 Installation setting

Circuit: sets the 3 characters tag for circuit.

Driver: sets the 3 characters tag for driver.

Cal-cal: calibrate the unit in the position it is. Automatic calibration is performed at power up.

Orientation: sets the orientation of the unit if needs to be installed differently from this installation manual, possible values: xyz, xzy, yxz, yzx, zxy, zyx. If an invalid configuration is entered, system keeps previous setting. Default configuration is xyz.

Test: Test Accident generation.

2.3.2.4 Utility commands

D, Display: display configuration parameters.

t: toggles verbose monitor, default on in USB mode and default off in VBatt mode.

reboot: reboot the system.

3 Installation Guide

3.1 ADR4 Equipment

The ADR4 must be fitted in such a position that it is readily accessible and possible to change between sessions without the need to remove any major components of the car. The unit should also be mounted where **the LED can be easily seen by the operator**; if this is not possible, a remote LED need to be wired to the appropriate output pin. The external LED response is as follows:

Status	External LED Response
Logging	ON
Accident stored	2HZ 1-1-0
Download active	2HZ 1-1-1-0

The ADR4 **must be mounted directly to the chassis** in order to give the best measurement of accident forces; however, the unit must not be mounted close to sources of extreme vibration such as around the engine or gearbox. An interface plate may be used to simplify the installation and strengthen the mounting surface to isolate the device from vibrations. In this case, the device must be in sufficient contact with the plate, and the plate must be in sufficient contact with the chassis.

The desired mounting and orientation of the ADR4 is one that is in alignment with the axis shown below and inside the driver "safety cell". It is important that care is taken to ensure that the ADR4 does not create an additional hazard to the driver during an accident.

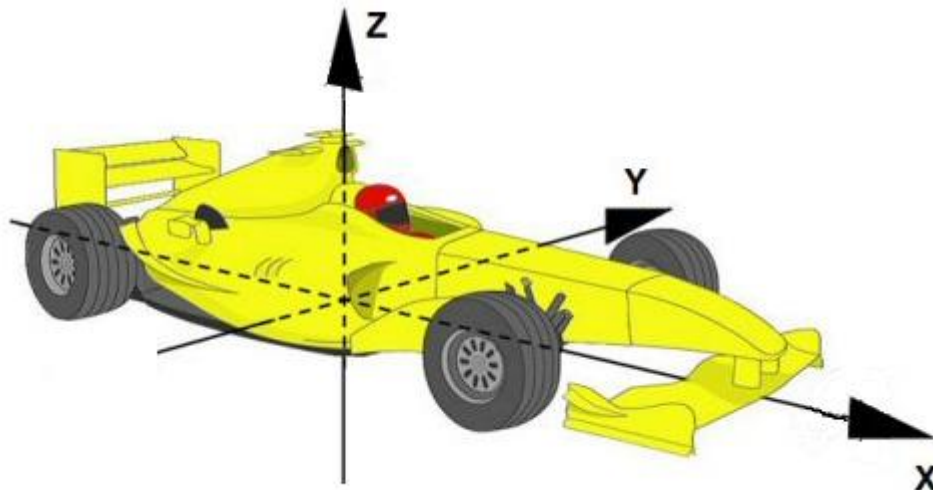

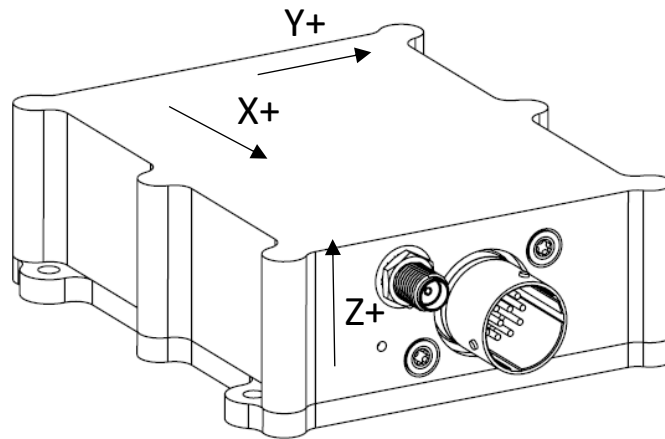

Figure 3 - Car & Device Coordinate Conventions

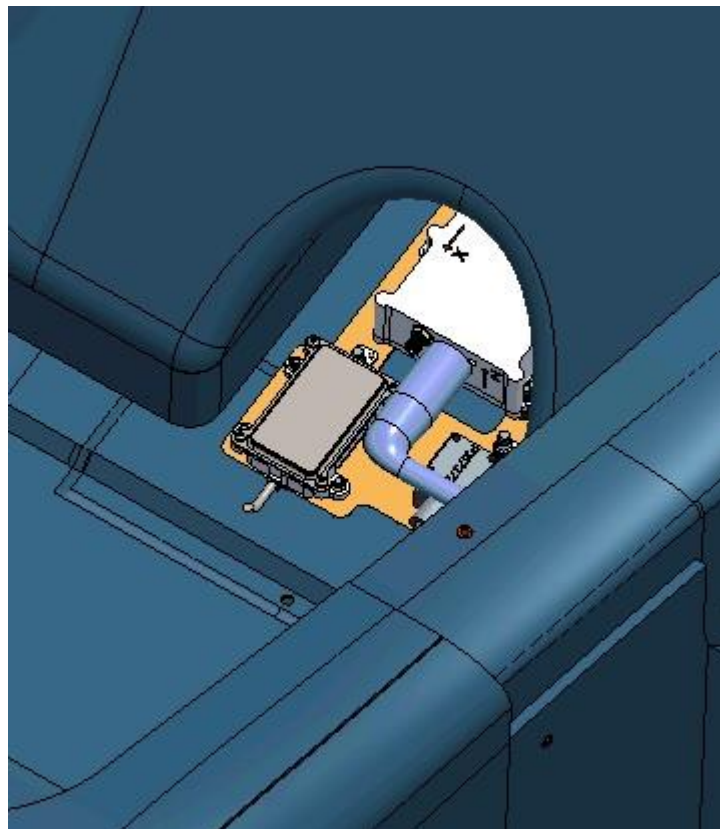

Figure 4 - Real placement of ADR using an interface plate. System is located within the monocoque, under the drivers' seat.

It is recommended that the RS232 and USB connectors are taken to an easily accessible "Download connector" so that accident data can be easily downloaded.

The ADR4 case is IP66 rated provided the correct connectors are used and proper sealing of the connectors are achieved and maintained. Special care must be taken to avoid the possibility that any fluid or object will cover the unit continuously.

The ADR4 internal temperature utilization range is -15°C - $+85^{\circ}\text{C}$, every care should be taken to maintain a temperature within the operating temperature range and so the ADR4 should be mounted away from areas of extreme heat, such as around the engine, gearbox, exhaust, braking components or radiators.

It is expressly **prohibited** to affix or mount any item to the ADR4 or modify the ADR4 equipment in any way. All the operations on the device have to be performed by the manufacturer.

The use of Velcro, double or single sided tape, rivets or anti-vibration mounts is prohibited in any of the interfaces between the device, chassis and interface plate. The ADR must be screwed directly to the chassis or to an interface plate, using 4 x M3 bolts, with the ADR placed perfectly horizontally. (AV mounts are permitted).



Figure 5 - Example of wrong installation

4 Car Looms

4.1 Chassis Loom

The ADR4 needs to be powered from the car power supply, with power consumption averaging less than 2.5W. During super capacitor charging phase, currents will temporarily be higher so car wiring should be designed to supply up to 500mA.

4.2 GPS Antenna Loom (optional)

- The connection at the ADR4 is a SMA female Jack (cable connector is a SMA male plug).
- Do not exceed minimum dynamic bending radius of the cables specified on the manufacturer's data sheet.

NB: If the ADR4 is being connected to a GPS antenna that is shared with a system already on the car, then a power isolating splitter should be used to ensure that the two antenna power supplies are not connected together.

5 Technical Description

5.1 ADR4 Technical information

Power Supply

- Voltage +8 - +19 V
- Nominal Current @13v 150 mA
- Peak Current @13v 500 mA (during charging phase)

Environmental

- Operating Temperature Ranges
 - Internal -10 - +60°C
 - Guaranteed ADR functionalities (GPS off) -15 - +85°C
- Protection Class IP66
- Max impact survival >1000G

Mechanical

- Height (max incl. connector) 28 mm
- Width (max) 72mm
- Length (max) 85mm
- Weight <175g
- Main Connector Deutsch (AS2-10-35 PN)
- GPS Antenna Connector SMA Female

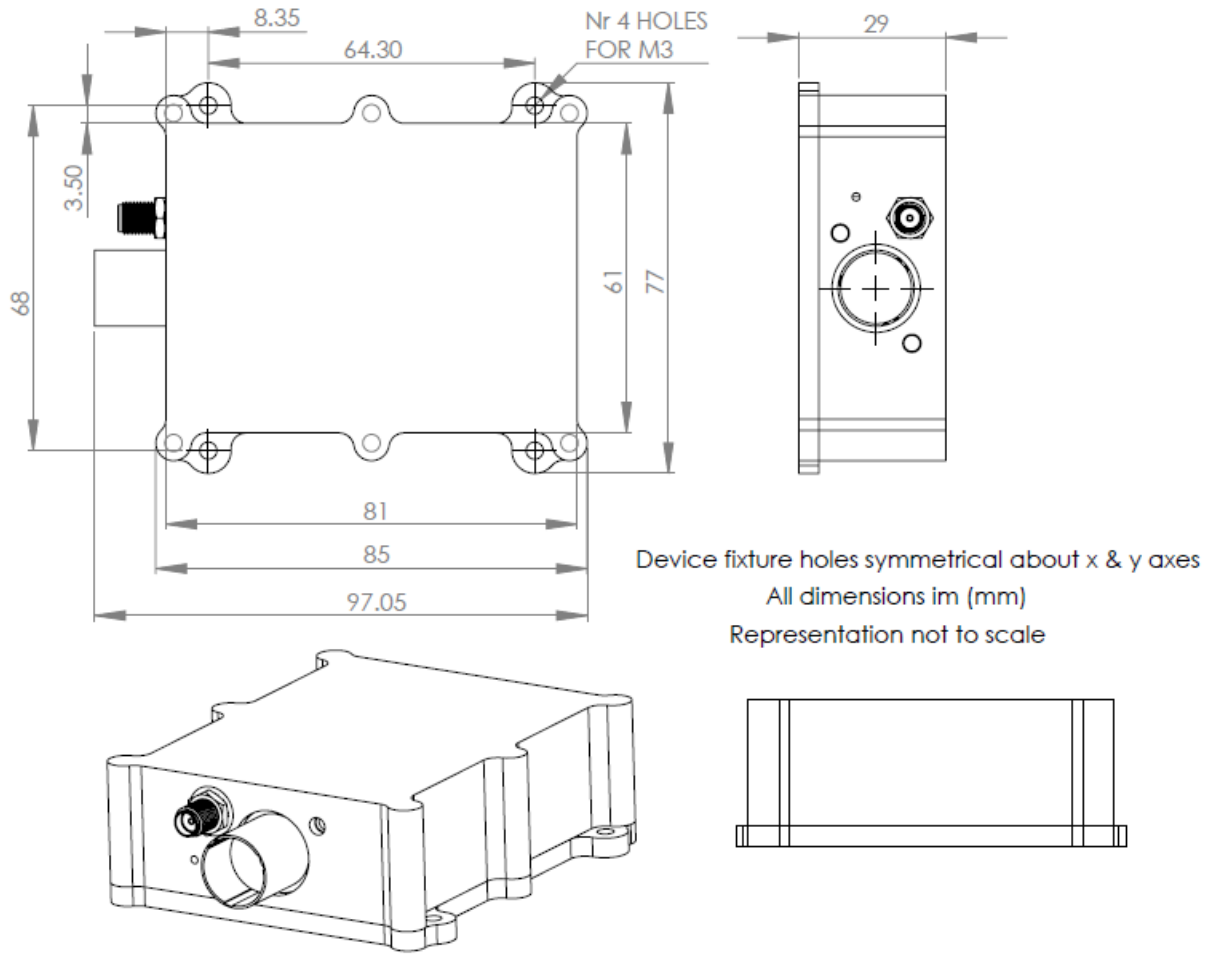

Figure 6 - ADR 4 Drawing

5.2 ADR4 System Loom Technical Data

5.2.1 ADR4 terminal

ADR4 Connector AS 2 10-35 PN
 Harness connector AS 6 10-35 SN

Pin	Function	Note.
1	RS232-RX Serial	
2	Digital Input 2	
3	CAN-P	
4	CAN-N	
5	Output 100mA LS	
6	GND, USB_VBUS-N	Download
7	USB_VBUS-P	Download
8	USB_D-P	Download
9	USB_D-N	Download
10	RS232-TX Serial	
11	Digital Input 1	
12	VBATT +	
13	GND, USB_VBUS-N	Download

Table 3 – ADR 4 Pin out



Figure 7 – Master keyway orientation

6 CAN Protocol

The ADR4 uses the CAN bus to:

- receive data to be logged from the ECU
- send/receive the GPS/inertial sensor information
- send the logger/accident status

The CAN protocol used in ADR4 has been defined by the FIA in the 8872-2018 Standard, and further modifications or amendments to the CAN protocol are not possible without FIA permission.

6.1 Input packets

6.1.1 ECU to ADR4 (CAN ID 0x200)

Message ID: **0x200**
Message rate: **f = 100Hz**
Format: **Big Endian**

Byte	Description	Scaling	Type
0-1	Engine Rotational Speed	rpm/bit	16-bit unsigned
2	Front Brake Pressure	bar/bit	8-bit unsigned
3	Rear Brake Pressure	bar/bit	8-bit unsigned
4-5	Lap Distance	1 m/bit	16-bit unsigned
6-7	Throttle actuator position	0.1 %/bit	16-bit signed

Message 1: ID 0x200, rate 100Hz

6.1.2 ECU to ADR4 (CAN ID 0x204)

Message ID: **0x204**
Message rate: **f = 100Hz**
Format: **Big Endian**

Byte	Description	Scaling	Type
0-1	Vehicle speed	0.1 km/h/bit	16-bit unsigned
2-3	Steer angle	°/bit	16-bit signed
4-5	Throttle pedal position	0.1 %/bit	16-bit signed

Message 2: ID 0x204, rate 100Hz

6.1.3 ECU to ADR4 (CAN ID 0x680)

Message ID: **0x680**
Message rate: **f = 10Hz**
Format: **Big Endian**

Byte	Description	Scaling	Type
0-3	GPS Latitude	1e7 degrees	32-bit signed
4-7	GPS Longitude	1e7 degrees	32-bit signed

Message 3: ID 0x680, rate 10Hz

6.1.4 ECU to ADR4 (CAN ID 0x681)Message ID: **0x681**Message rate: **f=10Hz**Format: **Big Endian**

Byte	Description	Scaling	Type
4-5	GPS Speed	0.1 km/h/bit	16-bit unsigned

Message 4: ID 0x681, rate 10Hz

6.2 Output packets

6.2.1 ADR4 to ECU (CAN ID 0x7B)

Message ID: **0x7B**
 Message rate: **f = 10Hz**
 Format: **Big Endian**

Byte	Description	Scaling	Type
0	Accident Severity Index	0 = no accident 1-255 = severity of last accident detected since power on	8-bit unsigned
1	ADR software version	10 (0x25=37d=>3.7)	8-bit unsigned
2-3	ADR Status	See Table 4	bitmapped
4-5	ADR serial number	-	16-bit unsigned
6-7	Car ID	MS first	16-bit Signed

Message 6: ID 0x7B, rate 10Hz

Bit	Description	Note
0	Logging in progress	1 if logger is in LOGGING state, else 0.
1	Logging config OK	1 if configuration table is OK, else 0.
2	CAN Team OK	1 if ADR is receiving CAN messages from ECU, else 0.
3	Accident stored	1 if an accident is stored in memory, else 0.
4	Accident active	1 if an accident is being detected
5	Download Mode	1 when USB is connected for data download
6-15	0	Always zero

Table 4: ADR Status

6.2.2 ADR4 to ECU (CAN ID 0x81)

Message ID: **0x81**
 Message rate: **f = 100Hz**
 Format: **Big Endian**

Byte	Description	Scaling	Type
0-1	Yaw rate	8.75 mdps/bit	16-bit signed
2-3	Acc Y (G-Lateral)	0.006125 g/bit	16-bit signed
4-5	Acc X (G-Longitudinal)	0.006125 g/bit	16-bit signed
6-7	Acc Z (G-Vertical)	0.006125 g/bit	16-bit signed

Message 7: ID 0x81, rate 100Hz

7 Useful Links

- eTS Analysis Tool + ADR Real Time Display:

<https://www.emmotorsport.com/solutions/adr#downloads>

- User: ADR4
- Password: ADR4



8 Contact Details

For further information, please contact the following;

EM Motorsport Ltd.

Unit A4 Telford Road

Bicester

Oxfordshire

OX26 4LD

U.K.

Tel: +44 (0)1869 241977

Email :

Support:

Giles Cooper: Business Development Manager

technical@emmotorsport.com

support@emmotorsport.com

gcooper@emmotorsport.com